

## VT-P PN40 PISTON CHECK VALVE SCREWED END

SIZE: 1/4"~2"

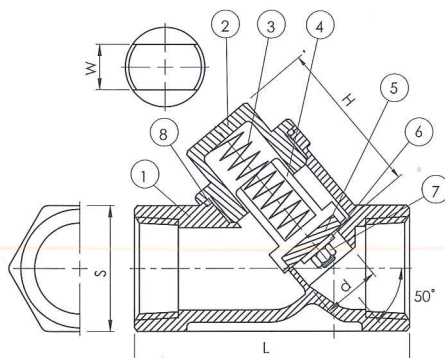
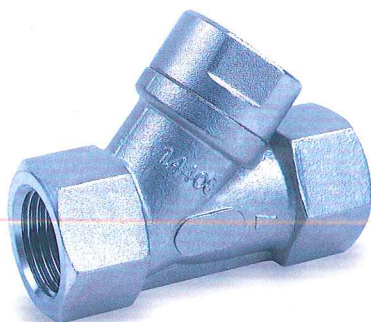

ITEM	PARTS	MATERIAL
1	BODY	ASTM-A351-CF8M
2	CAP	ASTM-A351-CF8M
3	SPRING	AISI 316
4	DISC	AISI 316
5	SEAT	PTFE
6	WASHER	AISI 304
7	NUT	AISI 304
8	JOINT GASKET	PTFE

- FEATURES:**
- \*Investment casting body & cap.
  - \*PN40 rating.
  - \*Maximum working temperature 230°C.
  - \*The end-to-end length conforms to Din 3203. Part 4. M8 series. (PN40)
  - \*Thread ends conform to ANSI B2.1, BS2.1, DIN 259/2999 standard, ISO228

SIZE	d	L	S	H	W
1/4"	11.6	65.5	27	38	24
3/8"	12.5	65.5	27	38	24
1/2"	12.5	65.5	27	36	24
3/4"	18	75.5	32	44	30
1"	23.5	90.5	41	57	35
1-1/4"	31.4	111	50	64	40
1-1/2"	35.7	121	55.5	76	45
2"	45.5	151	70	87	55

## VT-S PN40 SHUT-OFF VALVE

SIZE: 1/4"~2"

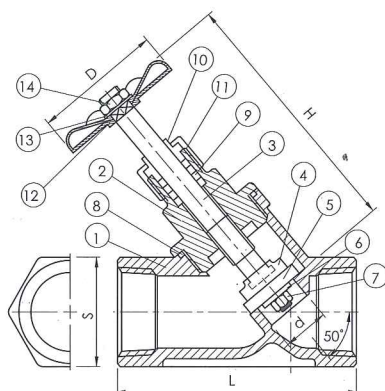
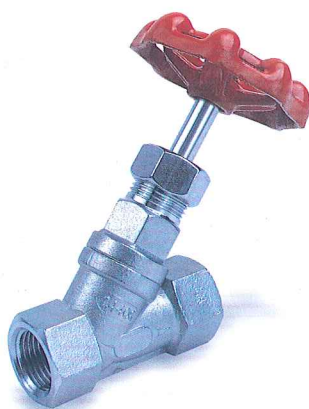

ITEM	PARTS	MATERIAL
1	BODY	ASTM-A351-CF8M
2	BONNET	ASTM-A351-CF8M
3	STEM	AISI 316
4	DISC	AISI 316
5	SEAT	PTFE
6	WASHER	AISI 304
7	NUT	AISI 304
8	JOINT GASKET	PTFE
9	STEM PACKING	PTFE
10	GLAND	AISI 304
11	PACKING NUT	AISI 304
12	HANDWHEEL	MALLEABLE IRON
13	WASHER	AISI 304
14	NUT	AISI 304

- FEATURES:**
- \*Investment casting body
  - \*PN40
  - \*Max. working temperature 230°C.
  - \*The end-to-end length conforms to Din 3202 Part 4. M8 series. (PN40)
  - \*Thread ends conform to ANSI B2.1, BS2.1, DIN 259/2999. ISO 228

SIZE	d	L	S	H	D
1/4"	11.6	65.5	27	97	62
3/8"	12.5	65.5	27	97	62
1/2"	12.5	65.5	27	97	62
3/4"	18.0	75.5	32	110	62
1"	23.5	90.5	41	117	83
1-1/4"	31.4	111	50	138	83
1-1/2"	35.7	121	55.5	150	114
2"	45.5	151	70	168	114