

VT-WCF SWING CHECK VALVE 10K/150LBS FLANGE END STAINLESS STEEL/CARBON STEEL

SIZE: 1/2"~12"

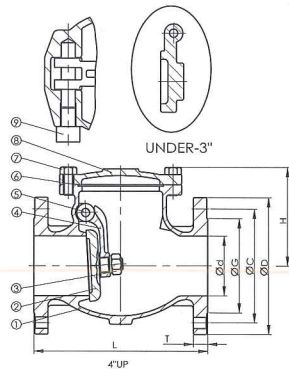

DIMENSIONS	150LBS				mm			
	SIZE	d	L	H	D 10K 150	C 10K 150	G 10K 150	T 10K 150
1/2"	15	15	112	65	95 89	70 60.5	52 35	12 11.1
3/4"	20	20	125	70	100 98	75 70	58 43	14 11.1
1"	25	25	135	75	125 108	90 79.5	70 51	14 11.1
1-1/2"	40	40	165	107	140 127	105 98.5	85 73	16 14.3
2"	50	50	203	120	155 152	120 120.5	100 92	16 15.9
2-1/2"	65	65	216	135	175 178	140 139.5	120 105	18 17.5
3"	80	80	241	147	185 190	150 152.5	130 127	18 19.1
4"	100	100	292	169	210 229	175 190.5	155 157	18 23.9
5"	125	125	330	190	250 254	210 216	185 186	20 23.9
6"	150	150	356	213	280 279	240 241.5	215 216	22 25.4
8"	200	200	495	253	330 343	290 298.5	265 270	22 28.6
10"	250	250	622	279	400 406	355 362	325 324	24 30.2
12"	300	300	698	312	445 483	400 432	370 381	24 31.8

TEST PRESSURE

SHELL (BY HYDRAULIC)	450 PSI
	32kg/cm ²
SEAT	BY HYDRAULIC 315PSI
	22kg/cm ²
	PNEUMATIC 80PSI
	6kg/cm ²

MATERIALS LIST

NO.	PART NAME	MATERIAL
1	BODY	SCS13/CF8 SCS14/CF8M
2	DISC	SCS13/CF8 SCS14/CF8M
3	NUT	SS304
4	ARM HINGE	SCS13/CF8 SCS14/CF8M
5	HINGE PIN	SS304 SS316
6	GASKET	PTFE (OR NO ASBESITOS)
7	BOLT	ASTM A194-B8/A194-2H
8	BONNET	SCS13/CF8 SCS14/CF8M
9	BOLT	SS304

FEATURES

FACE TO FACE DIMENSIONS: JIS B2002 / ANSI B16.10
 END FLANGE DIMENSIONS: JIS B2239 / ANSI B16.5
 DESIGN: ANSI B16.34
 TEST: API 589
 INVESTMENT CASTING BODY

VT-YF Y-STRAINERS 10K/150LBS FULL PORT, FLANGE END CF8M/CF8/WCB/CAST IRON

SIZE: 1/2"~10"

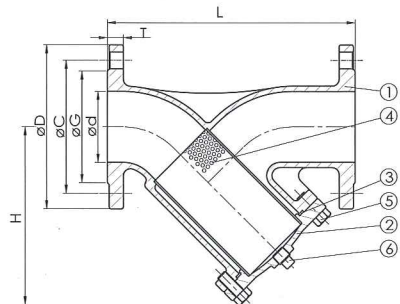

FEATURES

FACE TO FACE DIMENSIONS: JIS B2002 / ANSI B16.10
 END FLANGE DIMENSIONS: JIS B2239 / ANSI B16.5
 DESIGN: ANSI B16.34
 TEST: API 589
 INVESTMENT CASTING BODY

MATERIAL LIST

NO	PART NAME	MATERIALS		
1	BODY	SCS13	SCS14	WCB
2	BONNET	SCS13	SCS14	WCB
3	GASKET	PTFE		
4	SCREEN	SUS304		
5	BONNET BOLT	ASTM A194-B8/A194-2H		
6	STOPPER	SUS304		

DIMENSIONS 150LBS

DIMENSIONS	150LBS				mm			
	SIZE	d	L	H	D 10K 150	C 10K 150	G 10K 150	T 10K 150
1/2"	15	15	120	75	95 89	70 60.5	52 35	12 11.1
3/4"	20	20	140	75	100 98	75 70	58 43	14 11.1
1"	25	25	150	100	125 108	90 79.5	70 51	14 11.1
1-1/2"	40	40	190	120	140 127	105 98.5	85 73	16 14.3
2"	50	50	210	140	155 152	120 120.5	100 92	16 15.9
2-1/2"	65	65	250	175	175 178	140 139.5	120 105	18 17.5
3"	80	80	280	196	185 190	150 152.5	130 127	18 19.1
4"	100	100	340	244	210 229	175 190.5	155 157	18 23.9
5"	125	125	380	277	250 254	210 216	185 186	20 23.9
6"	150	150	420	320	280 279	240 241.5	215 216	22 25.4
8"	200	200	500	390	330 343	290 298.5	265 270	22 28.6
10"	250	250	730	508	400 406	355 362	325 324	24 30.2

SCREEN SPECIFICATION

SIZE	PERFORATION
1/2"-11/4"	1.5MM
1 1/2"-10"	2MM

